

VIST-250

• OVERVIEW

A reimagined design icon—empowering creativity to redefine modern architecture with timeless beauty.

A bold expression of minimalist design, the Vista Collection transforms architectural spaces with its continuous double-triangle motif. Striking yet refined, it delivers both style and functionality with effortless precision. For added stability in walls exceeding 2 meters in height, structural reinforcement is recommended.



• MODEL

Each Jonite product model represents a unique combination of design, durability, and precision engineering, tailored to meet diverse architectural requirements.

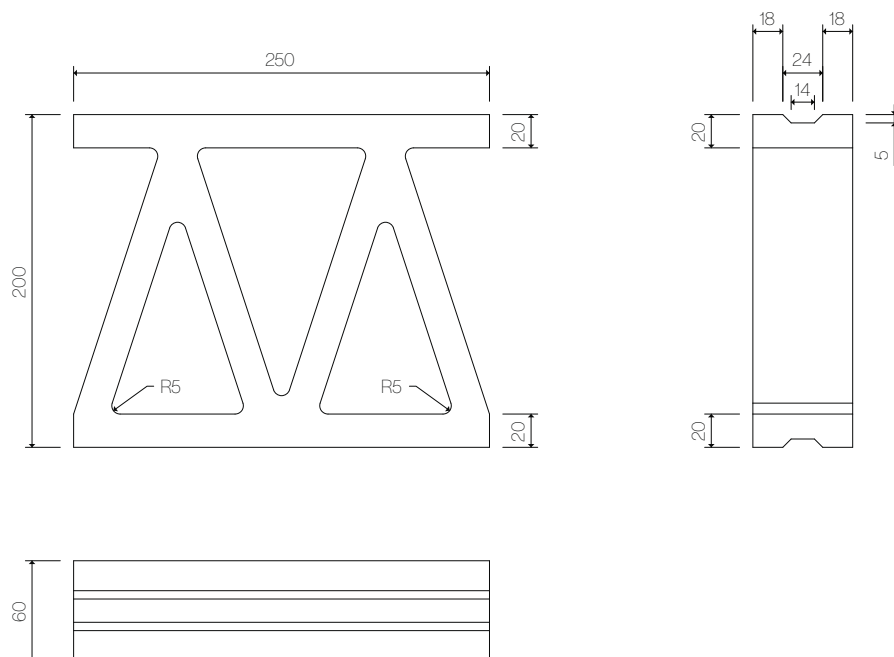

● TECHNICAL INFORMATION

DIMENSIONS

W: 200mm
L: 250mm
H: 60mm

OPEN AREA

27051 mm² (54%)

COMPRESSIVE STRENGTH

60 MPa

WEIGHT

3.5 kg





● APPLICATIONS

Crafted for both aesthetic expression and functional performance, Jonite breeze blocks offer a unique way to sculpt space with purpose.

From façades and feature walls to courtyard screens and garden partitions, each piece allows light and air to pass through while offering privacy and structural definition. Ideal for indoor or outdoor use, Jonite breeze blocks are modular elements that bring form and function together beautifully.

● TESTING & COMPLIANCE

Jonite products undergo stringent quality testing to ensure they meet international standards, providing reliable performance and safety across various applications.

| TEST | STANDARD | RESULT | APPLICATIONS |
|--|----------------------|--|---|
|  Surface Spread of Flame | BS 476 Part 7 | Class 1 | Complies with fire safety for indoor or facade applications. |
|  Salt Spray Test | ASTM B117 | No red rust or visible changes after 48h | Suitable for most outdoor environment. |
|  Water Absorption | SS245:1995 | 0.09% | Ensures long-term durability in wet and dry outdoor environments. |
|  Compressive Strength | ASTM C140 / 140M-24a | 60.4 N/mm ² (Average) | Suitable for load-bearing or structural architectural applications. |

● INTEGRITY & SUSTAINABILITY

Every Jonite product is created with eco-conscious practices, combining long-lasting durability with sustainable design to reduce environmental impact.

REGULATIONS



RECOGNITION



● CONFIGURATIONS

Interchangeable units in this breeze block collection allow for diverse configurations. Easily create unique patterns, facades, or screens to match any design vision.

Elevate your design projects by leveraging the ability to mix and match these units with our comprehensive range of breeze block collections. Witness the possibilities with these configuration examples:

